

FIXING DETAIL

100mm Fire-rated Partitions

Issue: 001

Document Number: HYG005

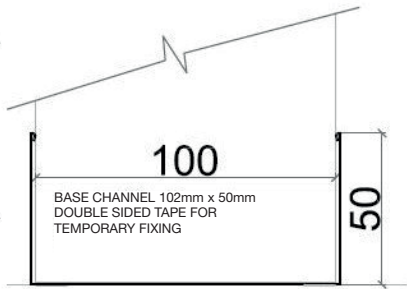

BASE CHANNEL

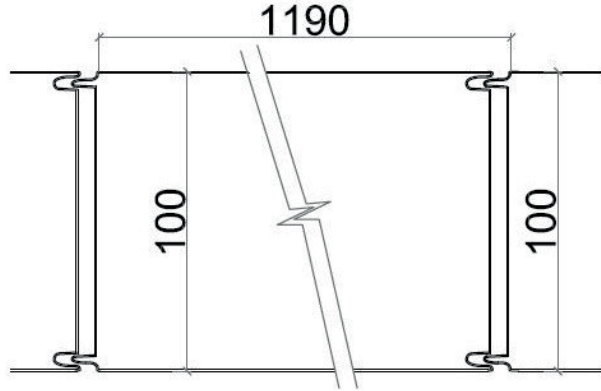

PANEL JOINTS

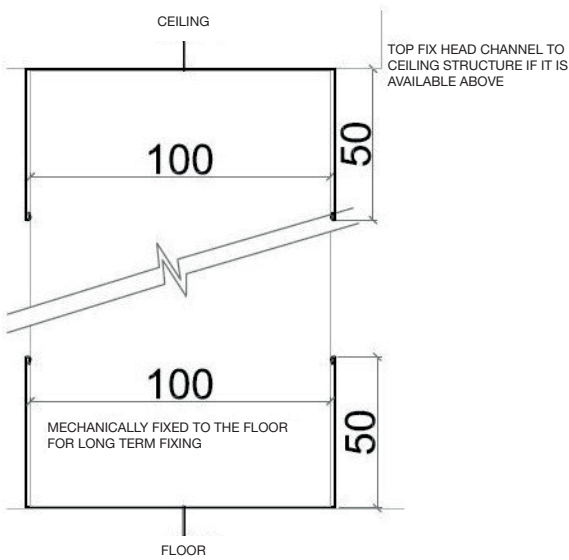

HEAD & BASE CHANNEL

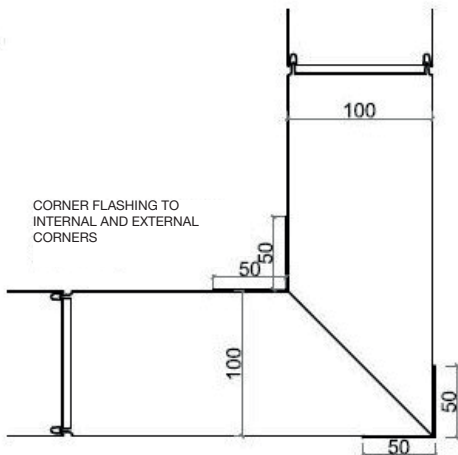

MITRED CORNER

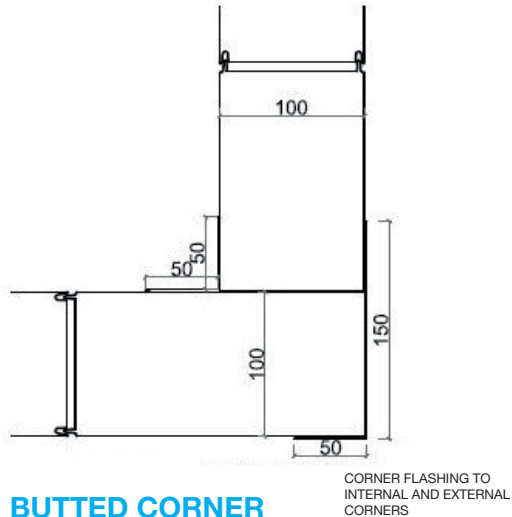

BUTTED CORNER

Document Number: HYG005

Our 100mm Fire-Rated Partitions are food safe and offer insulation and soundproofing benefits. They create sturdy and professional internal partition walls and can also be used to create walk-on ceilings.

Panels are 1190mm wide and offer a half-hour, one-hour and two-hour fire-rating. The standard thickness is 100mm and we also offer 150mm and 200mm versions. Panels are available in heights of 3m to 10m and are normally fitted floor-to-ceiling using head and base channels (with minimal visible fixings).

Please call **01274 578 051** for advice on the most suitable partition panels for your project. Standard panels are white, but colours are available on request.

For further information or technical advice

Call [01274 578 051](tel:01274578051)

Email: info@hygienee.com

www.hygienee.com

